

NUMBER THEORY CASTING A LOOK AT THE MIRROR

W. ZUDILIN

September 27, 2000

To A. B. Shidlovskii on the occasion of his 85th birthday

ABSTRACT. In this work, we give a purely analytic introduction to the phenomenon of mirror symmetry for quintic threefolds via classical hypergeometric functions and differential equations for them. Starting with a modular map and recent transcendence results for its values, we regard a mirror map $z(q)$ as a concept generalizing the modular one. We give an alternative approach demonstrating the existence of non-linear differential equations for the mirror map, and exploit both an elegant construction of Klemm–Lian–Roan–Yau and the Ax theorem to prove that the Yukawa coupling $K(q)$ does not satisfy any algebraic differential equation of order less than 7 with coefficients from $\mathbb{C}(q)$.

It is a classical question of transcendence number theory to investigate linear and algebraic independence of values of analytic functions satisfying both arithmetic conditions and functional (for instance, differential) equations. This story has many dramatic and romantic episodes (like the solution of the 7th Hilbert problem), but it is far from an end.

Skipping results about the transcendence of one-variable modular functions and their values, we concentrate on what has been done in 1996. The Mahler conjecture about the transcendence of at least one among the numbers $q \in \mathbb{C}$, $0 < |q| < 1$, and $J(q)$, where $J(e^{2\pi i\tau})$ is a modular invariant, has been proved in [BDGP]. Yu. Nesterenko has generalized this result using the Ramanujan functions and differential equations for them; in [Ne] he has proved that at least three among the numbers q , $J(q)$, $\delta_q J(q)$, and $\delta_q^2 J(q)$, for $q \in \mathbb{C}$ such that $0 < |q| < 1$ and $J(q) \notin \{0, 1728\}$, are algebraically independent over \mathbb{Q} , where $\delta_q = q \frac{d}{dq}$. It can be a subject of an independent paper to overview consequences of the results of [BDGP] and [Ne]; moreover, we believe that the rich nature of modular functions will bring many new results on the transcendence of mathematical constants. The general theorem which allows one to apply the approach suggested there to other analytic functions satisfying differential equations has been also proved in [Ne]. But all known (to us) non-linear differential systems with ‘nice’ (in some arithmetic sense) solutions have the modular nature.

1991 *Mathematics Subject Classification*. 11J91, 33C20, 14J32 (Primary), 32J35, 32S40 (Secondary).

A recent observation of physicists in string theory has given a job to mathematicians specializing in algebra and geometry. This observation, called *mirror symmetry*, is nothing more than usual modularity in the simplest cases. We are not planning here a lengthy discussion of the mirror referring to wonderful articles on this subject (see [BS], [M1]–[M3]). Our aim is to work out an approach to mirror symmetry as a philosophy generalizing modular, in particular, as a good task for number theorists and analysts. Below we make an attempt to describe mirror symmetry analytically, without any physics and algebraic geometry.

1. MODULARITY AS A MOTIVATION

Let us start from the solution $f_0(z)$ analytic at $z = 0$ of the second order linear differential equation

$$(\delta_z^2 - 3z(3\delta_z + 1)(3\delta_z + 2))y = 0, \quad \text{where } \delta_z = z \frac{d}{dz}. \quad (1)$$

One finds that $f_0(z)$ is the hypergeometric G -function with expansion

$$f_0(z) = \sum_{l=0}^{\infty} \frac{(3l)!}{(l!)^3} z^l = {}_2F_1\left(\frac{1}{3}, \frac{2}{3}; 1; 3^3 z\right)$$

in a neighbourhood of $z = 0$. Since the equation (1) has unipotent monodromy at the point $z = 0$, another solution of (1) is of the form $f_1(z) = f_0(z) \log z + g(z)$, where

$$g(z) = 3 \sum_{l=1}^{\infty} \left(\frac{(3l)!}{(l!)^3} \sum_{k=l+1}^{3l} \frac{1}{k} \right) z^l$$

in a neighbourhood of $z = 0$. It is non-obvious to see that the function

$$\begin{aligned} q(z) &= \exp\left(\frac{f_1(z)}{f_0(z)}\right) = z \cdot \exp\left(\frac{g(z)}{f_0(z)}\right) \\ &= z + 15z^2 + 279z^3 + 5729z^4 + 124554z^5 + 2810718z^6 + 65114402z^7 + O(z^8) \end{aligned}$$

has integral coefficients in its z -expansion, so the same property holds for the q -expansion of the inverse function

$$z(q) = q - 15q^2 + 171q^3 - 1679q^4 + 15054q^5 - 126981q^6 + 1024952q^7 + O(q^8).$$

Moreover, we have the expansion

$$\tilde{f}_0(q) = f_0(z(q)) = 1 + 6q + 6q^3 + 6q^4 + 12q^7 + 6q^9 + 6q^{12} + 12q^{13} + 6q^{16} + 12q^{19} + O(q^{21}),$$

which converges for $q \in \mathbb{C}$ with $|q| < 1$, and

$$f_0^2(z(q)) = \left(\frac{\delta_q z(q)}{z(q)} \right) \cdot \frac{1}{1 - 3^3 z(q)} \quad (2)$$

(see, e.g., [LY2] or [Z]). These observations can be explained by the modular origin of functions $z(q)$ and $\tilde{f}_0(q)$ with respect to the parameter $\tau = \frac{1}{2\pi i} \log q \in \mathfrak{H} = \{\tau \in \mathbb{C} : \Im\tau > 0\}$ and the congruence level 3 subgroup

$$\Gamma_0(3) = \left\{ \begin{pmatrix} a & b \\ c & d \end{pmatrix} \in SL_2(\mathbb{Z}) : c \equiv 0 \pmod{3} \right\}$$

(see [LY2], [HM], [Z]): each of these functions satisfies a third order non-linear algebraic equation over \mathbb{Q} with respect to δ_q -derivation, where $\delta_q = q \frac{d}{dq} = \frac{1}{2\pi i} \frac{d}{d\tau}$, and, due to Mahler [Ma] (see also [Ni]), does not satisfy any equation over $\mathbb{C}(q)$ of a smaller order.

Note that $f_0(z)$ and $q(z) = \exp(f_1(z)/f_0(z))$ are multi-valued functions of $z \in \mathbb{C} \setminus \{3^{-3}\}$; the function $z(q)$ is analytic for $q \in \mathbb{C}$ with $|q| < 1$ except simple poles at points q such that $\tau = \frac{1}{2\pi i} \log q$ is congruent to $\frac{1}{\sqrt{3}} e^{\pi i/6} = \frac{1}{2} + \frac{i}{2\sqrt{3}}$ with respect to $\Gamma_0(3)$ (see the fundamental domain of this group on Fig. 1). But locally, in a neighbourhood of $z \in \mathbb{C} \setminus \{0, 3^{-3}\}$, for any fixed branches of $f_0(z)$ and $q(z)$, the fields

$$\mathbb{Q}(z, q(z), f_0(z), \delta_z f_0(z)) \quad \text{and} \quad \mathbb{Q}(q, z(q), \tilde{f}_0(q), \delta_q \tilde{f}_0(q)) \quad (3)$$

coincide up to algebraic extension.

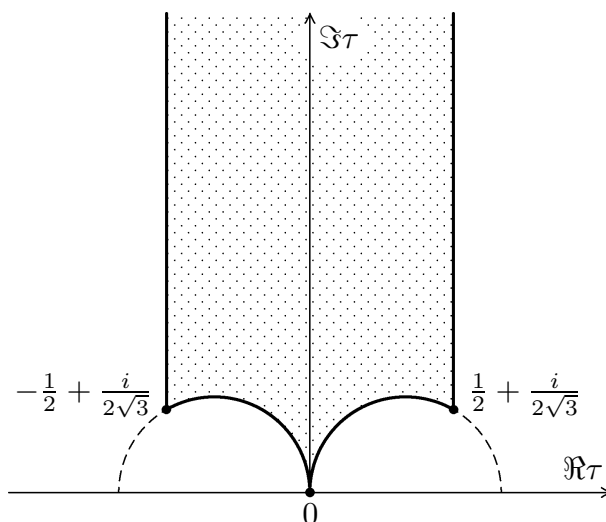

FIG. 1. Fundamental domain of $\Gamma_0(3)$

One consequence of Nesterenko's result [Ne] cited above is the algebraic independence of at least three among the numbers q , $z(q)$, $\tilde{f}_0(q)$, and $\delta_q \tilde{f}_0(q)$ for each q , $0 < |q| < 1$, such that $z(q) \notin \{0, 3^{-3}\}$. From the coincidence (up to algebraic extension) of the fields (3) we deduce the following result.

Theorem 1. *For each $z \in \mathbb{C} \setminus \{0, 3^{-3}\}$, at least three numbers among z , $q(z)$, $f_0(z)$, and $\delta_z f_0(z)$ are algebraically independent over \mathbb{Q} .*

Note that there is no general approach to transcendence (and even irrationality!) proofs for values of G -functions.

Now, we go on to the third order linear differential equation

$$(\delta_z^3 - 4z(4\delta_z + 1)(4\delta_z + 2)(4\delta_z + 3))y = 0 \quad (4)$$

and take two its solutions $f_0(z)$ analytic at $z = 0$ and $f_1(z) = f_0(z) \log z + g(z)$, where

$$f_0(z) = \sum_{l=0}^{\infty} \frac{(4l)!}{(l!)^4} z^l = {}_3F_2\left(\frac{1}{4}, \frac{2}{4}, \frac{3}{4}; 1, 1; 4^4 z\right),$$

$$g(z) = 4 \sum_{l=1}^{\infty} \left(\frac{(4l)!}{(l!)^4} \sum_{k=l+1}^{4l} \frac{1}{k} \right) z^l$$

in a neighbourhood of $z = 0$. Once again, the function

$$q(z) = \exp\left(\frac{f_1(z)}{f_0(z)}\right) = z \cdot \exp\left(\frac{g(z)}{f_0(z)}\right)$$

$$= z + 104z^2 + 15188z^3 + 2585184z^4 + 480222434z^5 + 94395247376z^6 + O(z^7)$$

has integral coefficients in its z -expansion, and the inverse function

$$z(q) = q - 104q^2 + 6444q^3 - 311744q^4 + 13018830q^5 - 493025760q^6 + O(q^7)$$

has integral coefficients in its q -expansion; moreover, the q -expansion

$$\tilde{f}_0(q) = f_0(z(q)) = 1 + 24q + 24q^2 + 96q^3 + 24q^4 + 144q^5 + 96q^6 + 192q^7 + 24q^8 + O(q^9)$$

with integral coefficients converges for $q \in \mathbb{C}$, $|q| < 1$, and

$$f_0^2(z(q)) = \left(\frac{\delta_q z(q)}{z(q)} \right)^2 \cdot \frac{1}{1 - 4^4 z(q)} \quad (5)$$

(see [LY2]). Theorem 1 (with the change 3^{-3} by 4^{-4}) holds for these new functions, since

$$f_0(z) = \sum_{l=0}^{\infty} \frac{(4l)!}{(l!)^4} z^l = \left({}_2F_1\left(\frac{1}{8}, \frac{3}{8}; 1; 4^4 z\right) \right)^2$$

(see [LY2], [Z]) and equation (4) is the symmetric square of the second order linear differential equation

$$(\delta_z^2 - 4z(8\delta_z + 1)(8\delta_z + 3))y = 0,$$

which has a modular explanation like the equation (1).

2. NATURAL GENERALIZATION

It is natural to continue the modular story of the previous section by considering now the linear differential equation

$$(\delta_z^{s-1} - sz(s\delta_z + 1)(s\delta_z + 2) \cdots (s\delta_z + s - 1))y = 0, \tag{6}$$

where $s \geq 3$ is an integer. Writing

$$f(z; H) = z^H \sum_{l=0}^{\infty} z^l \frac{\prod_{k=1}^{sl} (sH + k)}{\prod_{k=1}^l (H + k)^s} \pmod{H^{s-1}}, \tag{7}$$

where

$$z^H = e^{H \log z} = 1 + H \log z + H^2 \frac{\log^2 z}{2} + \cdots + H^{s-2} \frac{\log^{s-2} z}{(s-2)!} \pmod{H^{s-1}},$$

one can verify that the functions f_0, f_1, \dots, f_{s-2} from the formal expansion

$$f(z; H) = f_0(z) + f_1(z)H + \cdots + f_{s-2}(z)H^{s-2}$$

form the fundamental solution to the equation (6). By (7), we have z -expansions

$$f_0(z) = g_0(z) = \sum_{l=0}^{\infty} \frac{(sl)!}{(l!)^s} z^l, \tag{8}$$

$$f_1(z) = g_0(z) \log z + g_1(z), \quad \text{where} \quad g_1(z) = s \sum_{l=1}^{\infty} \left(\frac{(sl)!}{(l!)^s} \sum_{k=l+1}^{sl} \frac{1}{k} \right) z^l$$

in a neighbourhood of $z = 0$.

The integrality of the expansions for

$$q(z) = \exp\left(\frac{f_1(z)}{f_0(z)}\right) = z \cdot \exp\left(\frac{g_1(z)}{g_0(z)}\right)$$

and, as a consequence, for the inverse function $z(q)$ has been recently proved by Lian and Yau [LY2] using Dwork's p -adic approach. We underline that no modular argument is known for $z(q)$ when $s \geq 5$; moreover, for $s \geq 5$, it is easy to show that $z(e^{2\pi i\tau})$ cannot be a modular function with respect to a congruence subgroup of $SL_2(\mathbb{Z})$ (that is a consequence of the structure of monodromy groups for equations like (6); see [BH] and Section 5 below; see also [D] for the answer to the question 'When is $z(q)$ a modular function?'). We call $q \mapsto z(q)$ the *mirror map* produced by differential equation (6), or by hypergeometric series (8). (One can see no real mirror in the construction above, but we would like to have a compact name for the map $z(q)$.)

Although the algorithm for deducing differential equations for a mirror map is known (see [LY1]), we give another approach via the *Wronskian formalism* in the

next section. In Section 4, we make a special emphasis on the extremely well studied non-modular case of $s = 5$. Finally, in Section 5, we prove some transcendence results for the mirror map and related functions.

Throughout this paper we use the following convention for the parameters t, τ, q :

$$t = \log q = 2\pi i\tau,$$

and for the corresponding derivations:

$$\delta_q = q \frac{d}{dq} = \frac{d}{dt} = \frac{1}{2\pi i} \frac{d}{d\tau}.$$

3. WRONSKIAN FORMALISM

In this section, we derive the algebraic differential equation satisfied by the inverse of a ratio of two independent solutions of a linear differential equation (with regular singular points). In the case of second order differential equations such is the *Schwarzian equation*

$$2Q(z) \left(\frac{dz}{dt} \right)^2 + \{z, t\} = 0, \quad (9)$$

where

$$\{z, t\} = \frac{d^3 z / dt^3}{dz/dt} - \frac{3}{2} \left(\frac{d^2 z / dt^2}{dz/dt} \right)^2$$

is the Schwarzian derivative, and $Q(z)$ is a rational function with poles of order at most two at the singular points. Note that scaling the parameter t in (9) has no effect on this equation; so, it remains true if we change t by τ .

We are following the approach of Chudnovsky [CC]. To deduce the desired equation for a general m th order linear differential equation

$$D[y] = \frac{d^m y}{dz^m} + a_1(z) \frac{d^{m-1} y}{dz^{m-1}} + \cdots + a_{m-1}(z) \frac{dy}{dz} + a_m(z) y = 0, \quad (10)$$

where the coefficients a_1, \dots, a_m are from a differentially closed field \mathcal{L} (usually, $\mathcal{L} = \mathbb{C}(z)$) with constant field \mathbb{C} , we need some properties of the Wronskian

$$W(f_0, \dots, f_{m-1}) = \det \left(\frac{d^k f_j}{dz^k} \right)_{k,j=0,1,\dots,m-1}.$$

By \mathcal{L}_1 we denote a differential extension of \mathcal{L} with the same constant field \mathbb{C} .

Lemma 1. *The Wronskian $W(f_0, \dots, f_{m-1})$ of elements $f_0, \dots, f_{m-1} \in \mathcal{L}_1 \supset \mathcal{L}$ is identically zero if and only if these elements are linearly dependent over the constant field \mathbb{C} .*

Lemma 2. Let $f_0, \dots, f_{m-1} \in \mathcal{L}_1 \supset \mathcal{L}$ be linearly independent over \mathbb{C} solutions of (10). Then

$$D[y] = \frac{W(y, f_0, \dots, f_{m-1})}{W(f_0, \dots, f_{m-1})}.$$

Lemma 3. For any collection $g, f_0, \dots, f_{m-1} \in \mathcal{L}_1$,

$$W(gf_0, \dots, gf_{m-1}) = g^m W(f_0, \dots, f_{m-1}).$$

First, for given m th order linear differential equation (10) we want to construct the (non-linear) differential equation satisfied by each ratio of two linearly independent solutions of (10). It is

$$R[t] = \frac{W(tf_0, tf_1, \dots, tf_{m-1}, f_0, f_1, \dots, f_{m-1})}{W^2(f_0, f_1, \dots, f_{m-1})} = 0,$$

where f_0, f_1, \dots, f_m are linearly independent solutions of (10). By Lemmas 1 and 2, the coefficients of $R[t]$ belong to the differentially closed field \mathcal{L} containing all coefficients of the equation (10); the order of differential operator $R[t]$ is $2m - 1$.

Using the well-known binomial formula for the multiple derivation of the product and eliminating higher-order derivatives of f_0, f_1, \dots, f_{m-1} from the last m columns in the numerator of $R[t]$, we get

$$R[t] = \frac{1}{W(f_0, \dots, f_{m-1})} \det \left(\sum_{l=1}^k \binom{k}{l} t^{(l)} \frac{d^{k-l} f_j}{dz^{k-l}} \right)_{k=m, m+1, \dots, 2m-1; j=0, 1, \dots, m-1},$$

which yields that $R[t]$ is a polynomial in $t', \dots, t^{(2m-1)}$ with coefficients from \mathcal{L} such that its leading term $t^{(2m-1)}$ has coefficient 1.

In the case $\mathcal{L} = \mathbb{C}(z)$ we make a transition from the variable z and the function $t(z)$ to the variable t and the function $z(t)$. Since the fraction fields

$$\mathbb{Q} \left(\frac{dt}{dz}, \frac{d^2t}{dz^2}, \dots, \frac{d^{2m-1}t}{dz^{2m-1}} \right) \quad \text{and} \quad \mathbb{Q} \left(\frac{dz}{dt}, \frac{d^2z}{dt^2}, \dots, \frac{d^{2m-1}z}{dt^{2m-1}} \right)$$

coincide, $R[t]$ becomes a rational function of $z', z'', \dots, z^{(2m-1)}$ with coefficients from $\mathbb{C}(z)$ or, equivalently, $R[t] = 0$ becomes a polynomial differential equation of $(2m - 1)$ th order with constant coefficients. Moreover, $z^{(2m-1)}$ enters this equation in the first power.

Applying this construction to the case of the linear differential equation (6) we obtain the following result.

Proposition 1. The mirror map produced by differential equation (6) satisfies an algebraic $(2s - 3)$ th order differential equation with coefficients from \mathbb{C} . Moreover, $z^{(2s-3)}$ is rational over the field $\mathbb{C}(z, z', \dots, z^{(2s-4)})$.

Remark. The algebraic equation constructed above coincides with the equation given by the algorithm from [LY1].

Now we present some preliminary results for our transcendence consideration in Section 5. Let f_0, f_1, \dots, f_{m-1} be a fundamental solution of the (Fuchsian) differential equation (10) with coefficients from $\mathbb{C}(z)$, in a neighbourhood of a non-singular point $z = z_0$. Then each of the functions

$$t_j(z) = \frac{f_j(z)}{f_0(z)}, \quad j = 1, \dots, m-1, \quad (11)$$

satisfies the same algebraic differential equation $R[t] = 0$. If \mathcal{L} denotes the Picard–Vessiot extension of $\mathbb{C}(z)$ corresponding to (10), then from the definition (11) we see that $t_j \in \mathcal{L}$ for all $j = 1, \dots, m-1$. Further, the field

$$\mathcal{K} = \mathbb{C} \left(z, t_j, \frac{dt_j}{dz}, \dots, \frac{d^{2m-2}t_j}{dz^{2m-2}} \right)_{j=1, \dots, m-1} \subset \mathcal{L} \quad (12)$$

is differentially stable. By Lemma 3,

$$f_0^m = \frac{W(f_0, f_1, \dots, f_{m-1})}{W(1, t_1, \dots, t_{m-1})}, \quad (13)$$

and we note that the numerator of (13)—the Wronskian of (10)—is an algebraic function since the equation (10) is Fuchsian. Thus, by (13) we derive that f_0 is algebraic over \mathcal{K} ; hence the same property holds for $f_j = t_j f_0$, $j = 1, \dots, m-1$. Therefore we have

Proposition 2. *The differentially stable fields \mathcal{K} and \mathcal{L} defined above coincide up to algebraic extension.*

Remark. As an easy consequence of Lemma 1 it is possible to deduce the linear equation satisfied by the functions (11), but the coefficients of this equation are not in $\mathbb{C}(z)$.

4. DIFFERENTIAL EQUATIONS FOR MIRROR MAP

In this section we make a special emphasis on the case $s = 5$ in (6). We start with a comparison of expansions with those holding in the modular cases of Section 1. In the case $s = 5$ we derive the q -expansions

$$z(q) = q - 770q^2 + 171525q^3 - 81623000q^4 - 35423171250q^5 - 54572818340154q^6 - 71982448083391590q^7 - 102693620674349200800q^8 + O(q^9), \quad (14)$$

$$\begin{aligned} \tilde{f}_0(q) &= f_0(z(q)) \\ &= 1 + 120q + 21000q^2 + 14115000q^3 + 13414125000q^4 + 15234972675120q^5 \\ &\quad + 19285869813670920q^6 + 26264963911492602000q^7 + O(q^8). \end{aligned} \quad (15)$$

Unfortunately, the convergence domain of the q -expansion (15) is not the disc $|q| < 1$.

Without using the results of Section 3, we now present a compact version of the δ_q -differential equation for the function $z(q)$ ([LY1]–[LY3]):

$$2Q(z) \left(\frac{dz}{dt} \right)^2 + \{z, t\} = \frac{2}{5} \frac{d^2 \log K}{dt^2} - \frac{1}{10} \left(\frac{d \log K}{dt} \right)^2 \quad (16)$$

(cf. (9)), where

$$\begin{aligned} Q(z) &= \frac{5^8}{4} \left(\frac{16}{5^5 z} + \frac{16}{1 - 5^5 z} + \frac{25}{(5^5 z)^2} + \frac{15}{(1 - 5^5 z)^2} \right) \\ &= \frac{5^8}{4} \cdot \frac{25 - 34 \cdot (5^5 z) + 24 \cdot (5^5 z)^2}{(5^5 z)^2 (1 - 5^5 z)^2} \end{aligned} \quad (17)$$

is a rational function and

$$\begin{aligned} K(q) &= 5 + \sum_{l=1}^{\infty} \frac{n_l l^3 q^l}{1 - q^l} \\ &= 5 + 2875q + 4876875q^2 + 8564575000q^3 + 15517926796875q^4 + O(q^5) \end{aligned} \quad (18)$$

is the so-called *Yukawa coupling*.

We cannot write the direct analogue of (2) and (5) in this case, but we have

$$f_0^2(z(q)) = \left(\frac{\delta_q z(q)}{z(q)} \right)^3 \cdot \frac{1}{1 - 5^5 z(q)} \cdot \frac{5}{K(q)} \quad (19)$$

(see, e.g., [BS]). Formula (19) can be regarded as the definition of the Yukawa coupling, although the original definition is based on the enumerative meaning of the numbers n_l in (18) (see [Pa]). The definition (19) and the integrality of the mirror map (14) yield the conclusion $\frac{1}{5}K(q) \in \mathbb{Z}[[q]]$ without any references to algebraic geometry.

Picking, as in (7), the fundamental solution f_0, f_1, f_2, f_3 of the equation

$$(\delta_z^4 - 5z(5\delta_z + 1)(5\delta_z + 2)(5\delta_z + 3)(5\delta_z + 4))y = 0 \quad (20)$$

we get

$$\begin{aligned} f_0(z) &= g_0(z), & f_1(z) &= g_0(z) \log z + g_1(z), \\ f_2(z) &= g_0(z) \frac{\log^2 z}{2} + g_1(z) \log z + g_2(z), \\ f_3(z) &= g_0(z) \frac{\log^3 z}{6} + g_1(z) \frac{\log^2 z}{2} + g_2(z) \log z + g_3(z), \end{aligned}$$

where

$$\begin{aligned} g_0(z) &= 1 + 120z + 113400z^2 + 168168000z^3 + 305540235000z^4 + O(z^5), \\ g_1(z) &= 770z + 810225z^2 + \frac{3745679000}{3}z^3 + \frac{4627120640625}{2}z^4 + O(z^5), \\ g_2(z) &= 575z + \frac{4208175}{4}z^2 + \frac{16964522000}{9}z^3 + \frac{180021646778125}{48}z^4 + O(z^5), \\ g_3(z) &= -1150z - \frac{3298375}{4}z^2 - \frac{46661619875}{54}z^3 - \frac{325329574909375}{288}z^4 + O(z^5) \end{aligned}$$

are analytic functions. Taking

$$t(z) = \frac{f_1(z)}{f_0(z)} = \log q(z) = 2\pi i\tau(z) \quad (21)$$

for a new variable and

$$t_j(t) = \frac{f_j(z(t))}{f_0(z(t))}, \quad j = 0, 1, 2, 3, \quad (22)$$

for the new functions, we obtain for (22) the differential equation

$$\frac{d^2}{dt^2} \frac{1}{K(e^t)} \frac{d^2}{dt^2} t_j = 0, \quad j = 0, 1, 2, 3$$

(see [Pa]), where K is the Yukawa coupling. Moreover, we can explicitly describe functions (22). Namely, taking a *prepotential*

$$F(t) = \frac{5}{6}t^3 + \sum_{l=1}^{\infty} N_l q^l = \frac{5}{6}t^3 + \sum_{l=1}^{\infty} \sum_{k=1}^{\infty} \frac{n_l q^{kl}}{k^3},$$

and using the argument of [LY3] we obtain for the equation (20)

$$t_0(t) = 1, \quad t_1(t) = t \quad (\text{that is obvious}), \quad t_2(t) = \frac{1}{5} \frac{dF}{dt}, \quad t_3(t) = \frac{1}{5} t \frac{dF}{dt} - \frac{2}{5} F, \quad (23)$$

which, combined with (21) and (22), yields

$$F\left(\frac{f_1(z)}{f_0(z)}\right) = \frac{5}{2} \frac{f_1(z)f_2(z) - f_0(z)f_3(z)}{f_0^2(z)}.$$

Moreover, it is easy to see that

$$\frac{d^3 F}{dt^3}(t) = K(e^t) = K(q). \quad (24)$$

Remark. The functions

$$F_0(t) = \frac{1}{6}t^3 + \sum_{l=1}^{\infty} \sum_{k=1}^{\infty} \frac{240q^{kl}}{k^3}, \quad K_0(q) = \frac{d^3 F_0}{dt^3}(t) = 1 + \sum_{l=1}^{\infty} \frac{240l^3 q^l}{1 - q^l}$$

can be viewed as the ‘modular’ analogues of $F(t)$ and $K(q)$. The function $K_0(q)$ is a well known Ramanujan function, or an Eisenstein series regarded as a function of $\tau = \frac{1}{2\pi i} \log q$. Among properties of $F_0(t)$ we mention an arithmetic one: for $t = 2\pi i\tau = -2\pi$,

$$F_0(-2\pi) = \frac{10}{3}\pi^3 - 120\zeta(3), \quad \text{where} \quad \zeta(3) = \sum_{l=1}^{\infty} \frac{1}{l^3}$$

(see footnoted Ramanujan's identity in [Po]).

Now, we want to expose the results from [KLRy] and [LY3] on the existence of a differential equation for the Yukawa coupling. Moreover, as shown in these papers, there exists a duality between the differential equations for the mirror map and for the Yukawa coupling.

Any fourth order linear differential equation producing a mirror map with integral expansion can be reduced to the form

$$\frac{d^4 y}{dz^4} + Q_2(z) \frac{d^2 y}{dz^2} + \frac{Q_2(z)}{dz} \frac{dy}{dz} + Q_0(z)y = 0$$

(see [LY3]), where $Q_2(z)$ and $Q_0(z)$ are rational functions uniquely determined by the original equation (for instance, in the case of equation (20) one has $Q_2(z) = 10Q(z)$ with Q defined in (17)). Using primes for d/dt -derivatives and following [KLRy], [LY3] we set

$$\begin{aligned} A_2(z) &= Q_2(z)z'^2 + 5\{z; t\}, \\ A_4(z) &= Q_0(z)z'^4 + \frac{3}{2} \frac{dQ_2(z)}{dz} z'^2 z'' - \frac{3}{4} Q_2(z) z''^2 + \frac{3}{2} Q_2(z) z' z^{(3)} \\ &\quad - \frac{135}{64} \left(\frac{z''}{z'} \right)^4 + \frac{75}{4} \frac{z''^2 z^{(3)}}{z'^3} - \frac{15}{4} \left(\frac{z^{(3)}}{z'} \right)^2 - \frac{15}{2} \frac{z'' z^{(4)}}{z'^2} + \frac{3}{2} \frac{z^{(5)}}{z'}, \\ B_2(u) &= 2u'' - \frac{u'^2}{2}, \quad B_4(u) = \frac{u^{(4)}}{2} + \frac{u''^2}{4} - \frac{u'' u'^2}{2} + \frac{u'^4}{16}. \end{aligned}$$

Proposition 3 [KLRy]. *Given a pair of rational functions $Q_0(z), Q_2(z)$ (which determines the Picard–Fuchs equation), there exists a differential polynomial $P_1(\cdot, \cdot)$ with the following properties:*

- (i) P_1 is quasi-homogeneous;
- (ii) $P_1(A_2(z), A_4(z))$ is identically zero;
- (iii) $P_1(B_2(u), B_4(u)) = 0$ is a non-trivial seventh order differential equation in u with a solution $u(t) = \log K(e^t)$;
- (iv) P_1 is minimal, i.e. any differential polynomial satisfying (i)–(iii) has degree not less than P ;
- (v) the differential equation $P_1(B_2(u), B_4(u)) = 0$ is $SL_2(\mathbb{C})$ -invariant (that is, it is stable under a change of variable $t \mapsto (at+b)/(ct+d)$ for $\begin{pmatrix} a & b \\ c & d \end{pmatrix} \in SL_2(\mathbb{C})$).

The polynomial P_1 characterized by the properties (i)–(v) is unique up to a constant multiple.

We do not present here the complicated differential equation for the Yukawa coupling (18) described in Proposition 3, referring to an elegant algorithm for its construction and another example in [KLRy] and [LY3].

Proposition 4 [KLRy]. *There exists a differential polynomial $P_2(\cdot, \cdot)$ with the following properties:*

- (i) P_2 is quasi-homogeneous;

- (ii) $P_2(B_2(u), B_4(u))$ is identically zero;
- (iii) $P_2(A_2(z), A_4(z)) = 0$ is a non-trivial seventh order differential equation in z with a solution $z(e^t)$;
- (iv) P_2 is minimal of degree 12, i.e. any differential polynomial satisfying (i)–(iii) has degree at least 12;
- (v) the differential equation $P_2(A_2(z), A_4(z)) = 0$ is $SL_2(\mathbb{C})$ -invariant;
- (vi) P_2 is universal, i.e. it is independent of the data $Q_0(z), Q_2(z)$ and it is characterized by the properties (i)–(v) up to a constant multiple.

The equation $P_2(A_2(z), A_4(z)) = 0$ coincides with the equation deduced in Section 3.

As noted in [LY1] and proved in [LY3], it is possible to deduce coupled non-linear differential equations solved by the mirror map and the Yukawa coupling, e.g., (16) and

$$\tilde{Q}(z) \left(\frac{z'}{z} \right)^4 = \frac{175K'^4 - 280KK'^2K'' + 49K^2K''^2 + 70K^2K'K^{(3)} - 10K^3K^{(4)}}{K^4}, \quad (25)$$

where $\tilde{Q}(z)$ is a rational function depending on the original linear differential equation. In the case (20),

$$\begin{aligned} \tilde{Q}(z) &= -\frac{5750z + 63671875z^2 + 19531250000z^3}{(1 - 3125z)^4} \\ &= -\frac{1}{25} \frac{2 \cdot 5^5 z + 163 \cdot (5^5 z)^2 + 8 \cdot (5^5 z)^3}{(1 - 5^5 z)^4}. \end{aligned}$$

Proposition 5. *Let \mathcal{K}_0 be the algebraic closure over \mathbb{C} of the field generated by the function $K(q)$ and its δ_q -derivatives, where $\delta_q = q \frac{d}{dq} = \frac{d}{dt}$. Then the mirror map $z(q)$ is algebraic over \mathcal{K}_0 .*

Proof. By Proposition 3, the transcendence degree of \mathcal{K}_0 over \mathbb{C} is at most 7. We extend algebraically the field \mathcal{K}_0 to $\tilde{\mathcal{K}}_0$ by adding the element μ that is the root of the fourth degree of the right-hand side of (25); then the derivatives μ', μ'', \dots also belong to $\tilde{\mathcal{K}}_0$. It is sufficient to prove that $z(q)$ is algebraic over $\tilde{\mathcal{K}}_0$. To this end we rewrite (25) as follows:

$$z' = R(z) \cdot \mu, \quad \mu \in \tilde{\mathcal{K}}_0, \quad (26)$$

where $R(z)$ is an algebraic function of z , and take the logarithmic derivative of (26):

$$\frac{z''}{z'} = \frac{z'R'(z)}{R(z)} + \frac{\mu'}{\mu} = R'(z)\mu + \mu_1, \quad (27)$$

where we set $\mu_1 = \mu'/\mu \in \tilde{\mathcal{K}}_0$ and $R'(z)$ means derivative of $R(z)$ with respect to its intrinsic parameter z . Further, by (27) we obtain

$$\begin{aligned} \{z; t\} &= \left(\frac{z''}{z'} \right)' - \frac{1}{2} \left(\frac{z''}{z'} \right)^2 \\ &= (z'R''(z)\mu + R'(z)\mu\mu_1 + \mu_1') - \frac{1}{2} (R'^2(z)\mu^2 + 2R'(z)\mu\mu_1 + \mu_1^2) \\ &= \mu^2 \left(R(z)R''(z) - \frac{1}{2}R'^2(z) \right) + \left(\mu_1' - \frac{1}{2}\mu_1^2 \right). \end{aligned} \quad (28)$$

On the other hand, by (16) we obtain

$$\{z; t\} = -2Q(z)z'^2 + \mu_2 = -2Q(z)R^2(z)\mu^2 + \mu_2, \quad (29)$$

where $\mu_2 \in \mathcal{K}_0 \subset \tilde{\mathcal{K}}_0$ is the right-hand side of (16). Comparing (28) and (29) we see that

$$R(z)R''(z) - \frac{1}{2}R'^2(z) + 2Q(z)R^2(z) = \frac{1}{\mu^2} \left(\frac{1}{2}\mu_1^2 - \mu_1' + \mu_2 \right) \in \tilde{\mathcal{K}}_0. \quad (30)$$

Direct calculations show that the left-hand side of (30) is not identically zero, which means the algebraicity of z over $\tilde{\mathcal{K}}_0$ and, finally, over \mathcal{K}_0 . This completes the proof.

5. TRANSCENDENCE PROBLEMS OF MIRROR MAP

We are now able to state results on functional transcendence for the mirror map and for the Yukawa coupling. To do this, we apply the general method introduced in the joint works [BZ1] and [BZ2] of D. Bertrand and this author. We go back to notation of Section 3, where \mathcal{L} is the Picard–Vessiot extension corresponding to equation (20) and the field \mathcal{K} from (12) is d/dz -differentially stable.

Let $t = t_1$ be a new parameter. Since

$$\frac{d}{dt} = \left(\frac{dt}{dz} \right)^{-1} \frac{d}{dz},$$

we can consider the field \mathcal{K} as d/dt -differentially stable:

$$\mathcal{K} = \mathbb{C} \left(t, z, \frac{dz}{dt}, \dots, \frac{d^6 z}{dt^6}, t_2, \frac{dt_2}{dt}, \dots, \frac{d^6 t_2}{dt^6}, t_3, \frac{dt_3}{dt}, \dots, \frac{d^6 t_3}{dt^6} \right)$$

(provided that we are working locally, in a neighbourhood of non-singular point $z = z_0$). Finally, by (23) we obtain both $F \in \mathcal{K}$ and $t_2, t_3 \in \mathbb{C}[t, F, dF/dt]$, that is,

$$\mathcal{K} = \mathbb{C} \left(t, z, \frac{dz}{dt}, \dots, \frac{d^6 z}{dt^6} \right) \langle F \rangle_{d/dt} = \mathbb{C}(t) \langle z, F \rangle_{d/dt},$$

where $\mathcal{C} \langle F \rangle_{d/dt}$ is the algebraic closure of the field

$$\mathcal{C} \left(F, \frac{dF}{dt}, \frac{d^2 F}{dt^2}, \frac{d^3 F}{dt^3}, \dots \right)$$

(and \mathcal{C} is a d/dt -differentially stable field). By (24) and Proposition 3, the function $F(t)$ satisfies some tenth order algebraic differential equation.

Proposition 6. *The transcendence degree over $\mathbb{C}(t)$ of the field*

$$\mathcal{K} = \mathbb{C}(t) \langle z, F \rangle_{d/dt}$$

is 10.

Proof. By Proposition 2, the fields \mathcal{L} and \mathcal{K} coincide up to algebraic extension. Thus,

$$\mathrm{tr} \deg_{\mathbb{C}(t)} \mathcal{K} = \mathrm{tr} \deg_{\mathbb{C}} \mathcal{K} - 1 = \mathrm{tr} \deg_{\mathbb{C}} \mathcal{L} - 1 = \mathrm{tr} \deg_{\mathbb{C}(z)} \mathcal{L},$$

which is the dimension of the differential Galois group of (20). By [BH], the Zariski closure of the projective monodromy group of differential equation (20) (which is precisely its differential Galois group) is $Sp_4(\mathbb{C})$, and $\dim_{\mathbb{C}} Sp_4$ is 10. This completes the proof.

Remark. Of course, we must scale $z \mapsto 5^{-5}z$ to use the results of [BH] above and later.

Theorem 2. *The differentially closed field*

$$\mathcal{K}_1 = \mathbb{C}(t)\langle F \rangle_{d/dt}$$

coincides (up to algebraic extension) with the Picard–Vessiot extension \mathcal{L} corresponding to the linear differential equation (20). In particular,

- (a) $\mathrm{tr} \deg_{\mathbb{C}(t)} \mathcal{K}_1 = 10$;
- (b) *the mirror map $z(q) = z(e^t)$ is algebraic over \mathcal{K}_1 .*

Proof. The proof is an immediate consequence of Propositions 3, 5, and 6.

We need the following functional version of the Schanuel conjecture proved in [A].

The Ax theorem. *Let $h_1(\tau), \dots, h_m(\tau)$ be analytic functions in some neighbourhood of $\tau = 0$ such that $h_1(\tau) - h_1(0)$ are linearly independent over \mathbb{Q} . Then*

$$\mathrm{tr} \deg_{\mathbb{C}} \mathbb{C}(h_1(\tau), \dots, h_m(\tau), e^{h_1(\tau)}, \dots, e^{h_m(\tau)}) \geq m + 1,$$

provided that all exponentials are defined.

Proposition 7. *The function $q(t) = e^t$ is transcendent over \mathcal{K} .*

Proof. To describe the projective monodromy group of (20), it is reasonable to scale

$$t \mapsto \tau = \tau_1 = \frac{t}{2\pi i}, \quad t_2 \mapsto \tau_2 = \frac{t_2}{(2\pi i)^2}, \quad t_3 \mapsto \tau_3 = \frac{t_3}{(2\pi i)^3}, \quad z \mapsto \tilde{z} = 5^{-5}z.$$

Our aim is to prove the transcendence of $e^{\varkappa\tau}$ over \mathcal{K} for any $\varkappa \in \mathbb{C} \setminus \{0\}$.

The simplest way to express the projective monodromy group $G \subset GL_4(\mathbb{C})$ for the equation (20) in terms of \tilde{z} is given by the Levelt theorem (see [BH]). But in our case, studied in detail by physicists, we can use the ready result from [H] for the local monodromy $\gamma_1 \in G$ about $\tilde{z} = 1$ (we adopt our basis near $\tilde{z} = 0$ with the same one from [H]):

$$\begin{pmatrix} \tau_3 \\ \tau_2 \\ \tau_1 \\ 1 \end{pmatrix} \mapsto \gamma_1 \begin{pmatrix} \tau_3 \\ \tau_2 \\ \tau_1 \\ 1 \end{pmatrix}, \quad \gamma_1 = \begin{pmatrix} 1 & 0 & 0 & 0 \\ 0 & 1 & 0 & 0 \\ 0 & 0 & 1 & 0 \\ -1 & 0 & 0 & 1 \end{pmatrix}.$$

In particular, we have

$$\gamma_1^j : \tau \mapsto \frac{\tau}{1 - j\tau_3}$$

for any $j \in \mathbb{Z}$. We note that $\tau_3(\tau)$ is transcendental over $\mathbb{C}(\tau)$ by (23) and Theorem 2.

Functions $\tau/(1 - j\tau_3)$, $j = 0, 1, \dots, m$, where $m \in \mathbb{N}$ is arbitrary, are linearly independent over \mathbb{C} (and therefore, over \mathbb{Q}). By the Ax theorem, we get the algebraic independence over \mathbb{C} of at least m among $m + 1$ exponentials

$$\exp\left(\frac{\varkappa\tau}{1 - j\tau_3}\right), \quad j = 0, 1, \dots, m. \quad (31)$$

We fix $m \geq 12$. Assume now that $e^{\varkappa\tau}$ is algebraic over \mathcal{K} . Since the field \mathcal{K} is G -invariant, acting by γ_1^j we see that all exponentials (31) are algebraic over \mathcal{K} . The transcendence degree over \mathbb{C} of the field generated by exponentials (31) is at least $m \geq 12$, while the transcendence degree over \mathbb{C} of \mathcal{K} is 11 by Proposition 6. This contradiction completes the proof of the transcendence of $e^{\varkappa\tau}$ over \mathcal{K} .

Remark 1. Our arguments using $\gamma_1 \in G$ remain valid for other linear differential equations producing mirror maps (see [H]).

Remark 2. It is interesting to compare our approach of adding $q = e^{\varkappa\tau}$ with the approach in [Ni], where the author, roughly speaking, considers the exponentials $\exp(\varkappa\tau/(1 - j\tau))$ for $j = 1, 2, 3, 4$, and proves their algebraic independence over $\mathbb{C}(\tau)$ (rather than \mathbb{C}) from the linear independence of $\tau/(1 - j\tau)$, $j = 1, 2, 3, 4$, over \mathbb{C} . This proof is based on the Ostrowski–Kolchin theorem (which is also mentioned in [A] as a related result).

Remark 3. D. Bertrand (cf. [BZ2]) gives slightly different and easy arguments proving Proposition 7 (and the Mahler–Nishioka result from [Ma], [Ni]). Namely, when γ runs through G , the functions $\exp(\varkappa \cdot \gamma\tau)$ generate over \mathbb{C} a field of infinite transcendence degree; therefore, they cannot be algebraic over the field \mathcal{K} of finite transcendence degree. The key to the proof of this claim is the fact that each of the functions $\exp(\varkappa\tau/(1 - j\tau_3))$ has essential singularities in the set $S_j = \{\tau \in \mathbb{C} : \tau_3(\tau) = 1/j\}$, $j \in \mathbb{Z}$, thus it is transcendental over the field of functions meromorphic in a neighbourhood of $s_j \in S_j$; in particular, $\exp(\varkappa\tau/(1 - j\tau_3))$ is transcendental over the field generated over \mathbb{C} by other exponentials $\exp(\varkappa\tau/(1 - m\tau_3))$, $m \neq j$.

Now, results on functional transcendence take their ‘close to final’ form.

Theorem 3. *The transcendence degree over \mathbb{C} of the field $\mathbb{C}(t, q = e^t)\langle F \rangle_{d/dt}$ is 12.*

Theorem 4. *The transcendence degree over $\mathbb{C}(q)$ of the field*

$$\mathcal{K}_2 = \mathbb{C}(q)\langle K(q) \rangle_{\delta_q} = \mathbb{C}(q)\langle K(q) \rangle_{d/dq}$$

is 7, where $K(q)$ is the Yukawa coupling. In other words, $K(q)$ does not satisfy an algebraic differential equation of order less than 7 with coefficients from $\mathbb{C}(q)$.

Remark 1. The same results can be received for other mirror maps and Yukawa couplings considered in [M2] and [BS].

Remark 2. The result of Theorem 4 would be more useful if there existed a set $\theta_1(q), \dots, \theta_7(q)$ of generators of \mathcal{K}_2 such that

- (i) functions $\theta_1(q), \dots, \theta_7(q)$ have integral coefficients of *polynomial* growth in their q -expansions,
- (ii) these functions satisfy a (more or less) simple system of non-linear differential equations.

Condition (i) is crucial for making number-theoretic applications, while (ii) can simplify algebraic preliminaries.

Remark 3. It is natural to consider the differential field

$$\mathcal{K}_3 = \mathbb{C}(q)\langle z(q) \rangle_{\delta_q} = \mathbb{C}(q)\langle z(q) \rangle_{d/dq},$$

since the seventh order differential equation for $z(q)$ is simpler than for $K(q)$. However, in spite of the differential duality observed in [KLR] and [LY3], we know of no arguments for $K(q)$ to be algebraic over \mathcal{K}_3 .

Acknowledgements. This work is an extended version of author's talk on the International Conference on Transcendental Numbers held at Moscow, September 18–22, 2000. I express my gratitude to all participants of this meeting for their suggestive remarks. Special gratitude is due to Professor D. Bertrand for his careful reading of the preliminary version of this paper and for his valuable advice sharpening the description of the transcendence results. I am also grateful to Professor B. H. Lian for sending me the text of [LY3]. This work was supported in part by the INTAS–RFBR project no. IR-97-1904.

REFERENCES

- [A] J. Ax, *On Schanuel's conjectures*, Ann. of Math. (2) **93** (1971), 252–268.
- [BDGP] K. Barré, G. Diaz, F. Gramain, and G. Philibert, *Une preuve de la conjecture de Mahler–Manin*, Invent. Math. **124**:1 (1996), 1–9.
- [BS] V. V. Batyrev and D. van Straten, *Generalized hypergeometric functions and rational curves on Calabi–Yau complete intersections in toric varieties*, Comm. Math. Phys. **168**:3 (1995), 493–533; <http://xxx.lanl.gov/abs/alg-geom/9307010>.
- [BZ1] D. Bertrand and W. Zudilin, *On the transcendence degree of the differential field generated by Siegel modular forms*, Prépubl. de l'Institut de Math. de Jussieu, vol. 248, 2000; <http://xxx.lanl.gov/abs/math/0006176>.
- [BZ2] D. Bertrand and W. Zudilin, *Derivatives of Siegel modular forms and exponential functions*, Preprint, 2000, submitted for publication.
- [BH] F. Beukers and G. Heckman, *Monodromy for the hypergeometric function ${}_nF_{n-1}$* , Invent. Math. **95**:2 (1989), 325–354.
- [CC] D. V. Chudnovsky and G. V. Chudnovsky, *The Wronskian formalism for linear differential equations and Padé approximations*, Adv. Math. **53**:1 (1984), 28–54.
- [D] C. F. Doran, *Picard–Fuchs uniformization and modularity of the mirror map*, Comm. Math. Phys. **212** (2000), 625–647.
- [HM] J. Harnad and J. McKay, *Modular solutions to equations of generalized Halphen type*, Preprint CRM-2536, Univ. de Montréal, Montréal, 1998; <http://xxx.lanl.gov/abs/solv-int/9804006>.
- [H] S. Hosono, *Local mirror symmetry and type IIA monodromy of Calabi–Yau manifolds*, Adv. Theor. Math. Phys. **4** (2000); <http://xxx.lanl.gov/abs/hep-th/0007071>.

- [KLRY] A. Klemm, B. H. Lian, S. S. Roan, and S.-T. Yau, *A note on ODEs from mirror symmetry*, Functional analysis on the eve of the 21st century, Vol. II, In honor of the 80th birthday of I. M. Gelfand, Proceedings of a conference, held at Rutgers University (New Brunswick, NJ, USA, October 24–27, 1993) (S. Gindikin et al., eds.), Progress in Math., vol. 132, Birkhäuser, Boston, MA, 1996, pp. 301–323; <http://xxx.lanl.gov/abs/hep-th/9407192>.
- [LY1] B. H. Lian and S.-T. Yau, *Arithmetic properties of mirror map and quantum coupling*, Comm. Math. Phys. **176**:1 (1996), 163–192; <http://xxx.lanl.gov/abs/hep-th/9411234>.
- [LY2] B. H. Lian and S.-T. Yau, *Integrality of certain exponential series*, Lectures in Algebra and Geometry (M.-C. Kang, ed.), Proceedings of the International Conference on Algebra and Geometry, National Taiwan University (Taipei, Taiwan, December 26–30, 1995), International Press, Cambridge, MA, 1998, pp. 215–227; *Mirror maps, modular relations and hypergeometric series I*, <http://xxx.lanl.gov/abs/hep-th/9507151>.
- [LY3] B. H. Lian and S.-T. Yau, *Differential equations from mirror symmetry*, Surveys in Differential Geometry, Differential Geometry inspired by String Theory, vol. 5, International Press, Somerville, MA, 1999, pp. 510–526.
- [Ma] K. Mahler, *On algebraic differential equations satisfied by automorphic functions*, J. Austral. Math. Soc. **10** (1969), 445–450.
- [M1] D. R. Morrison, *Mirror symmetry and rational curves on quintic threefolds: A guide for mathematicians*, J. Amer. Math. Soc. **6** (1993), 223–247; <http://xxx.lanl.gov/abs/alg-geom/9202004>.
- [M2] D. R. Morrison, *Picard–Fuchs equations and mirror maps for hypersurfaces*, Essays on Mirror Manifolds (S.-T. Yau, ed.), International Press, Hong Kong, 1992, pp. 241–264; ———, *Mirror Symmetry I* (S.-T. Yau, ed.), AMS/IP Stud. Adv. Math., vol. 9, Amer. Math. Soc., Providence, RI, 1998, pp. 185–199; <http://xxx.lanl.gov/abs/alg-geom/9202026>.
- [M3] D. R. Morrison, *Mathematical aspects of mirror symmetry*, Complex Algebraic Geometry (J. Kollár, ed.), Lectures of a Summer Program (Park City, UT, 1993), IAS/Park City Math. Ser., vol. 3, Amer. Math. Soc., Providence, RI, 1997, pp. 267–340; <http://xxx.lanl.gov/abs/alg-geom/9609021>.
- [Ne] Yu. V. Nesterenko, *Modular functions and transcendence questions*, Sb. Math. **187**:9 (1996), 1319–1348.
- [Ni] K. Nishioka, *A conjecture of Mahler on automorphic functions*, Arch. Math. (Basel) **53**:1 (1989), 46–51.
- [Pa] B. Pandharipande, *Rational curves on hypersurfaces (after A. Givental)* [Exp. no. 848], Sémin. Bourbaki, vol. 1997/98, Exp. 835–849, Astérisque, vol. 252, Soc. Math. France, Montrouge, 1998, pp. 307–340; <http://xxx.lanl.gov/abs/math/9806133>.
- [Po] A. van der Poorten, *A proof that Euler missed... Apéry’s proof of the irrationality of $\zeta(3)$* , An informal report, Math. Intelligencer **1**:4 (1978/79), 195–203.
- [Z] W. Zudilin, *Hypergeometric equation and Ramanujan functions*, Preprint, 2000, submitted for publication.

MOSCOW LOMONOSOV STATE UNIVERSITY
DEPARTMENT OF MECHANICS AND MATHEMATICS
VOROBIOVY GORY, MOSCOW 119899 RUSSIA
E-mail address: wadim@ips.ras.ru